

STRAIGHT ADAPTORS

G-L

JIC MALE X NPTF MALE

JIC 37° MALE X NPTF MALE STRAIGHT

- SAE J514

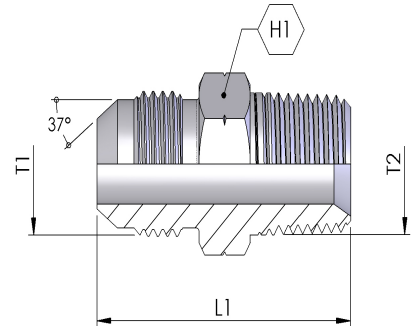

Part Number	T1	T2	H1 (mm)	L1 (mm)	PN (bar)
G-L-0702	7/16-20	1/8-27	12	31	345
G-L-0704	7/16-20	1/4-18	14	36	275
G-L-0706	7/16-20	3/8-18	19	36	210
G-L-0708	7/16-20	1/2-14	22	43	210
G-L-0802	1/2-20	1/8-27	14	31	345
G-L-0804	1/2-20	1/4-18	14	36	275
G-L-0806	1/2-20	3/8-18	19	36	210
G-L-0902	9/16-18	1/8-27	17	32	345
G-L-0904	9/16-18	1/4-18	17	36	275
G-L-0906	9/16-18	3/8-18	19	37	210
G-L-0908	9/16-18	1/2-14	22	43	210
G-L-0912	9/16-18	3/4-14	22	39	170
G-L-1204	3/4-16	1/4-18	22	39	275
G-L-1206	3/4-16	3/8-18	22	39	210
G-L-1208	3/4-16	1/2-14	22	46	210
G-L-1212	3/4-16	3/4-14	27	47	170
G-L-1406	7/8-14	3/8-18	24	43	210
G-L-1408	7/8-14	1/2-14	24	48	210
G-L-1412	7/8-14	3/4-14	27	50	170
G-L-1416	7/8-14	1-11.1/2	36	55	140
G-L-1706	1.1/16-12	3/8-18	30	57	210
G-L-1708	1.1/16-12	1/2-14	30	52	210
G-L-1712	1.1/16-12	3/4-14	30	52	170
G-L-1716	1.1/16-12	1-11.1/2	36	57	140
G-L-2112	1.5/16-12	3/4-14	36	54	170
G-L-2116	1.5/16-12	1-11.1/2	36	58	140
G-L-2120	1.5/16-12	1.1/4-11.1/2	46	61	80

G-L-2616	1.5/8-12	1-11.1/2	46	61	140
G-L-2620	1.5/8-12	1.1/4-11.1/2	46	62	80
G-L-2624	1.5/8-12	1.1/2-11.1/2	50	65	70
G-L-3020	1.7/8-12	1.1/4-11.1/2	50	67	80
G-L-3024	1.7/8-12	1.1/2-11.1/2	50	68	70
G-L-3032	1.7/8-12	2-11.1/2	65	73	70
G-L-4032	2-1/2-12	2-11.1/2	65	79	70